

\* front tractor unit parts

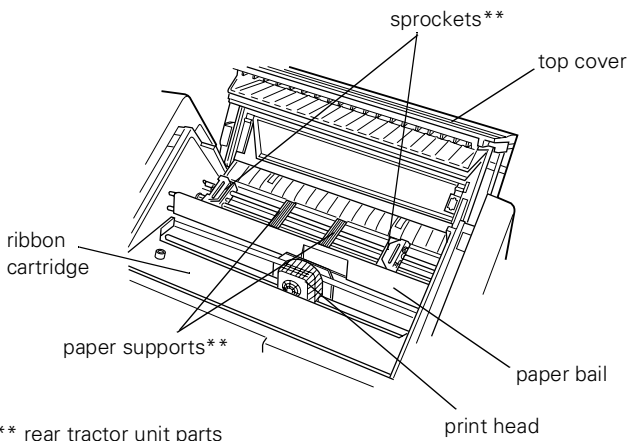

\*\* rear tractor unit parts

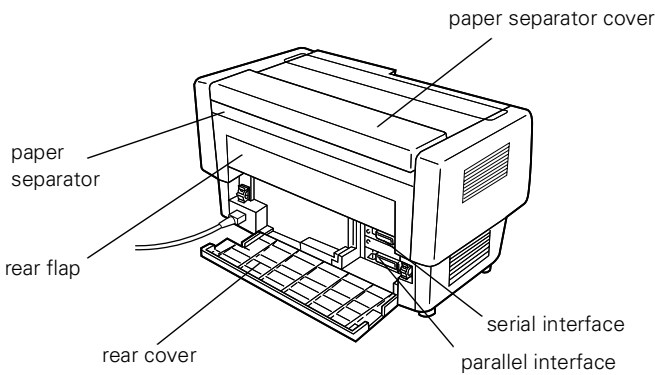

## Accessories

### Ribbon cartridge

Use the #8766 EPSON replacement cartridge only

## Printer Specifications

### Printing

Printing method: 9-pin impact dot matrix

Printing speed:

Characters per inch	Quality	Characters/second/line
10 cpi	High-speed draft	1120
10 cpi	Normal draft	840
10 cpi	Near letter quality	210
12 cpi	Draft	1008
12 cpi	Near letter quality	252

Printing direction: Bidirectional logic seeking for text and graphics printing. Unidirectional text or graphics printing can be selected using software commands.

Line spacing: 1/6-inch or programmable increments of 1/216-inch

Paper feed speed: Continuous  
0.25/m/sec/line (9.9 inches per second)

**Note:**

Paper feed speed drops to 6 inches per second when the optional pull tractor is mounted.

Printable columns:

Characters per inch	Maximum printed characters per column
10 cpi	136
12 cpi	163
15 cpi	204
17 cpi	233
20 cpi	272

Buffer: 128KB or 0KB (DIP switch selectable)

Character fonts: Characters per inch available

Font	Available pitches (cpi)
EPSON Super Draft	10
EPSON Draft	10, 12, 15
EPSON Roman (NLQ)	10, 12, 15, proportional
EPSON Sans serif (NLQ)	10, 12, 15, proportional

Character tables: One Italic and 10 graphical character tables. (26 graphical character tables are available in certain countries.)

Character sets: 13 international character sets

**Paper**

**Note:**

Use recycled paper, labels, envelopes, postcards, overlapping forms, and continuous forms with labels only under normal temperature and humidity conditions as follows:

Temperature 59° to 77°F (15° to 25°C)  
 Humidity 20% to 60% RH

**For continuous multi-part forms:**

- ❑ The form sheets of continuous multi-part forms should be securely joined together along the left and right edges by crimping or spot-gluing. For the best printing quality, use multi-part forms joined with spot-gluing.

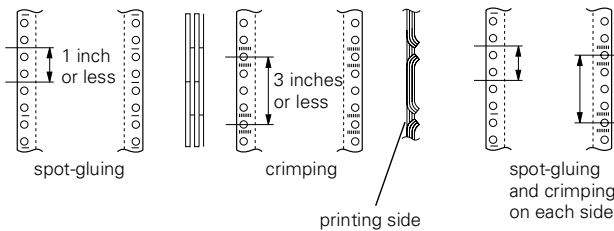

- ❑ When using crimped multi-part forms, note the following:
  - ❑ Crimping should be pressed in from the original sheet side and go completely through all copy sheets.
  - ❑ Crimping should be double-sided; using single-sided crimping may cause the printer to jam.

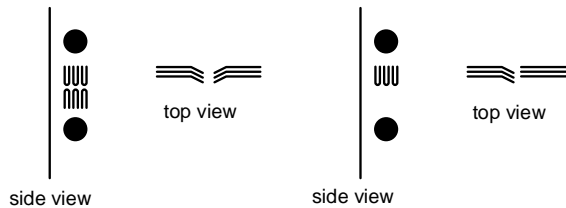

- ❑ Never use continuous multi-part forms that are joined with metal staples or bar-gluing.

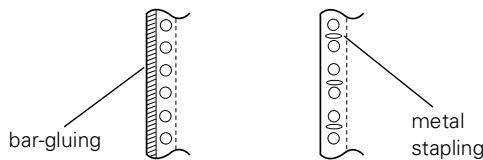

- ❑ The thickness of the folding part when extended should be the same as or less than the total thickness.

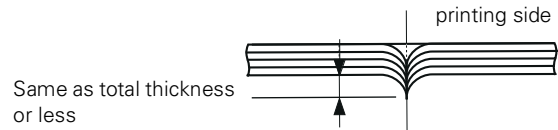

- ❑ The binding area should be flat and should have no creases.
- ❑ The sprocket holes of all sheets in the form should be aligned properly.
- ❑ The binding position should be outside the printable area.

Width: 4 to 16 inches (101 to 406 mm)

Length/page: 4 to 17 inches (101 to 431 mm)

Number of copies: Front 7 sheets (1 original + 6 copies)  
 Rear 6 sheets (1 original + 5 copies)

Total thickness: Front 0.021 inch (0.53 mm) maximum  
 Rear 0.018 inch (0.46 mm) maximum

Weight: Single sheets  
 14 to 22 lb (52.6 to 82.7 g/m<sup>2</sup>)

Multi-part forms  
 11 to 15 lb (41.4 to 56.4 g/m<sup>2</sup>) (weight/part) and within the total thickness

Quality: Plain, recycled, and carbonless paper

Printable area:

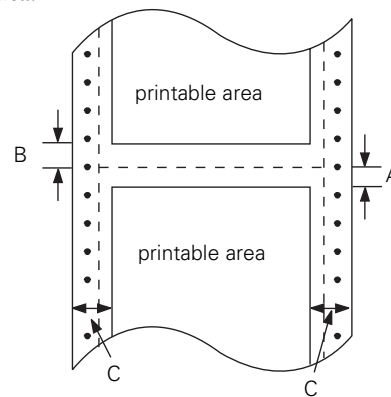

- A The minimum top margin (below the perforation) is 0.1 inch (2.6 mm).
- B The minimum bottom margin (above the perforation) is 0.165 inch (4.2 mm).
- C The minimum left or right margin is 0.51 inch (13 mm).  
 The maximum printable width is 13.6 inches (345.4 mm).

**Note:**

Position the sprockets or set your application software so that the printer does not print outside the printable area.

**Labels**

Size: 2.5 inches W × 15/16 inch H  
(63.5 mm W × 23.8 mm H)

4 inches W × 15/16 inch H  
(101 mm W × 23.8 mm H)

4 inches W × 17/16 inch H  
(101 mm W × 27.0 mm H)

Total thickness: 0.0075 inch (0.19 mm) maximum  
The difference in thickness must be less than 0.0047 inch (0.12 mm).

Quality: Plain paper or the same quality labels with continuous backing sheet

**Pre-printed paper**

Pre-printed paper is paper with white space in the middle and ruled lines, letters, or figures printed in the top and bottom margins. The margins are printed the first time the paper is loaded in the printer, and a document is printed in the white space the second time the paper is loaded in the printer. The margin areas are often used for letterheads, borders, and so on. You can make your own pre-printed paper or you can purchase it.

You cannot preprint in the area with the diagonal shading shown in the illustrations below, and you can preprint only with colors whose reflectivity is under 60% (for instance black). Avoid punching holes in the restricted area shown below because punctures are also recognized as colors whose reflectivity is under 60%.

Before printing on pre-printed sheets, verify that the area your document will print on does not overlap the pre-printed area by printing separate sample sheets and comparing their printed areas.

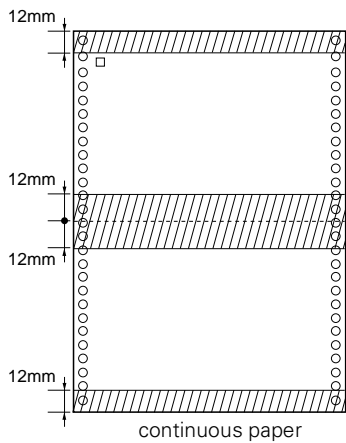

**Mechanical**

Paper feed methods: Push tractor (front and rear)  
Push-pull feed with optional pull tractor

Total print volume: 26 million lines (except print head)

Print head life: 400 million characters

Ribbon: Cartridge ribbon, available in black only (#8766). Do not use ribbons for 24-pin printers.  
Ribbon life expectancy is 15 million characters (at 14 dots/character).

Dimensions and weight:

Height: 14.5 inches (369 mm)

Width: 27.6 inches (700 mm)

Depth: 15.0 inches (382 mm)

Weight: approx. 64 lb (29 kg)

Duty cycle: 25%

**Electrical**

120 V model:

Rated voltage: AC 120 V

Input voltage range: AC 99 to 132 V

Rated frequency range: 50 to 60 Hz

Input frequency range: 49.5 to 60.5 Hz

Rated current: 3.5 A (max. 7.5 A)

Power consumption: Approx. 160 W (ISO/IEC 10561 Letter Pattern)  
Energy Star compliant

220–240 V model:

Rated voltage: AC 220 to 240 V

Input voltage range: AC 198 to 264 V

Rated frequency range: 50 to 60 Hz

Input frequency range: 49.5 to 60.5 Hz

Rated current: 1.4 A (max. 3.5 A)

Power consumption: Approx. 160 W (ISO/IEC 10561 Letter Pattern)  
Energy Star compliant

This product is also designed for IT power systems with Phase to Phase voltage 220–240V.

## Environmental

### Temperature:

Operation:	5°C to 35°C (41°F to 95°F)
Storage:	-30°C to 60°C (-22°F to 140°F)

### Humidity:

Operation:	10% to 80% RH without condensation
Storage:	5% to 85% RH without condensation

## Safety approvals

### 120 V model:

Safety standards:	UL1950 with D3 CSA C22.2 No. 950 with D3
EMI:	FCC part 15 subpart B class B CSA C108.8 class B

### 230 V model:

Safety standards:	EN 60950 (VDE, NEMKO)
EMI:	EN 55022 (CISPR pub. 22) class B AS/NZS 3548 class B

Acoustic noise: Approx. 58 dB (A) (ISO 7779 pattern)

## CE marking

### 230 V model:

Low Voltage Directive 73/23/EEC:	EN60950
EMC Directive 89/336/EEC:	EN55022 class B EN61000-3-2 EN61000-3-3 EN50082-1 IEC801-2 IEC801-3 IEC801-4

---

## Parallel Interface Specifications

---

The printer comes with a bidirectional, 8-bit, parallel interface and a Type-B optional interface slot.

### Forward channel

Transmission mode:	8-bit parallel, IEEE-1284 compatibility mode
Adaptable connector:	57-30360 (Amphenol) or equivalent

Synchronization:	$\overline{\text{STROBE}}$ pulse
Handshaking:	BUSY and $\overline{\text{ACKNLG}}$ signals
Signal level:	TTL compatible (IEEE-1284 level 1 device)

### Reverse channel

Transmission mode:	IEEE-1284 nibble mode
Adaptable connector:	57-30360 (Amphenol) or equivalent
Synchronization:	Refer to the IEEE-1284 specification
Handshaking:	Refer to the IEEE-1284 specification
Signal level:	IEEE-1284 level 1 device
Data transmission timing:	Refer to the IEEE-1284 specification
Extensibility request:	The printer responds to the extensibility request in the affirmative when the request is 00H or 04H, which means:
00H:	Request nibble mode of reverse channel transfer
04H:	Request device ID in nibble mode of reverse channel transfer

---

## Serial Interface Specifications

---

The DFX-8500 built-in serial interface is an RS-232C asynchronous interface with the following characteristics.

Data format:	1 start bit Data word length: 8 bits Odd, even, no parity, or ignore 1 or more stop bit
Signal level:	Mark logical "1" (-3 V to -25 V) Space logical "0" (+3 V to +25 V)
Handshaking:	Handshaking by DTR signal or Xon/Xoff
Bit rate:	2400, 4800, 9600, 19200 bps
Connector plug:	EIA 25-pin connector

## Control Panel Buttons and Lights

The control panel consists of indicator lights and buttons, and gives you access to several powerful features.

### Lights

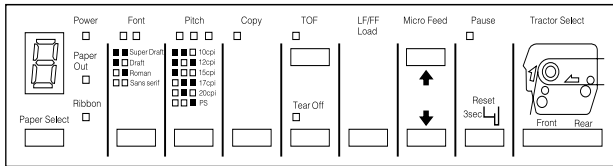

**Power** On when the power switch is on and power is supplied to the printer.

**Paper Out** On when the printer is out of paper. Comes on when there is no paper positioned behind the print head, even if paper is loaded on the tractors in the standby position.

Flashes when paper is jammed in the printer.

**Ribbon** Blinks when the ribbon is jammed in the printer.

**Paper Select** Displays the paper memory that is registered in the printer.

**Font** The font selection status is displayed by two font lights on the control panel:

- ■ Super Draft
- □ Draft
- ■ Roman
- □ Sans serif

□ = on, ■ = off

**Pitch** The pitch selection status is displayed by three pitch lights on the control panel:

- ■ □ 10 cpi
- □ ■ 12 cpi
- □ □ 15 cpi
- ■ ■ 17 cpi
- ■ □ 20 cpi
- □ ■ PS (Proportional Spacing)

□ = on, ■ = off

**Copy** On when the printer is in copy mode (to select darker printing).

**TOF (Top of Form)** On when the printer is in top-of-form mode. The printer remembers any change you make to the top-of-form position when this light is on.

**Tear Off** On when the printer is in tear-off mode. The printer remembers any change you make to the tear-off position when this light is on.

**Pause** On when printing is paused.

Blinks when the print head is hot. Press to temporarily stop printing and resume printing.

**Tractor Select Front** On when the front tractor is selected. The light is green when paper is loaded (even if the paper is in the standby position), and red when the tractor is out of paper.

**Tractor Select Rear** On when the rear tractor is selected. The light is green when paper is loaded (even if the paper is in the standby position), and red when the tractor is out of paper.

### Buttons

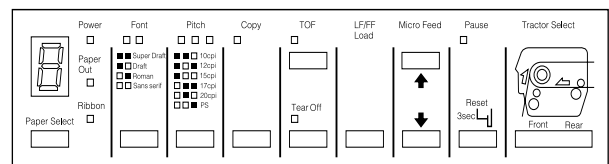

**Paper Select** Selects one of the following paper numbers: 1, 2, 3, 4, 5, 6, 7, 8, 0, a, or b.

Select a or b if you have registered paper information using the DIP switches and control panel.

Select 1 to 8 if you have registered paper information using the paper memory utility.

**Font** Selects one of the following fonts: Super Draft, Draft, Roman, or Sans Serif.

**Pitch** Selects the characters per inch for printing. Press the button until the light appears next to the desired pitch. (Your software setting overrides this setting.)

**Copy** Lets you print the document darker. This button is available in SuperDraft and Draft mode only and is disabled if you use the status monitor utility and select a paper number from 1 to 8.

**TOF (Top of Form)** When the top cover is open, lets you enter and exit the top-of-form mode to adjust the top-of-form position.

If your printing begins too high or low on the page, you can reset the top-of-form position by entering top-of-form mode and using micro feed to adjust the position. The printer remembers this new top-of-form position even after it is turned off, reset, or initialized. Also, the printer remembers separate top-of-form positions for the front and rear tractors.

**Tear Off** Feeds the paper to the printer's tear-off edge and puts the printer in tear-off mode.

If the perforation on your paper does not align exactly with the printer's tear-off edge, use the **Micro Feed** buttons to adjust the tear-off position.

This button can also be used to run the printer's NLQ self test.

 **CAUTION:** Never press the Tear Off button when labels are loaded in the printer. Use the LF/FF Load button to feed the printed labels to a point where they can be torn off.

**LF/FF Load** LF advances paper one line at a time. To feed your paper forward one line, press this button once.

FF advances continuous paper to the top of the next page. Press and hold the button for about one second.

Load loads paper on the push tractor of the selected paper path when no paper is currently loaded.

This button can also be used to run the draft self test.

**Micro Feed** These two buttons advance or reverse the loaded paper in 1/216-inch increments. The top button advances the paper and the bottom button reverses it. You can use these buttons to adjust the top-of-form, tear-off, and printing positions.

To reset the top-of-form position, press the **TOF** button to enter top-of-form mode. Then use the **Micro Feed** buttons to move the paper to the desired position.

To reset the tear-off position, press the **Tear Off** button to enter tear-off mode and feed the paper to the tear-off position. Then use the **Micro Feed** buttons to move the paper to the desired position.

To adjust the printing position, press either **Micro Feed** button to advance or reverse the paper to the desired position.

 **CAUTION:** When labels are loaded, use only the top Micro Feed button. Never feed labels backward through the printer.

**Pause** Press to temporarily stop printing. Press again to resume printing.

Hold down for at least 3 seconds to reset the printer's control panel settings.

**Tractor Select Front/Rear** Selects the front or rear tractor. If you have been using paper loaded on one tractor, first remove the printed output before pressing this button to switch the tractor. When you switch between tractors, the paper already loaded in the printer is fed backward to the standby position, and the paper on the newly selected tractor is loaded.

 **CAUTION:** Never use the Front/Rear button when labels are loaded in the printer. Always tear off any printed pages or excess paper so you don't feed more than one page backward through the printer.

## Other control panel features

- Self test** By holding down the **LF/FF Load** or **Tear Off** button while you turn on the printer, you can start the printer's self test. The self test prints the characters in the printer's ROM (Read Only Memory).
- Hex dump** By holding down both the **LF/FF Load** and **Tear Off** buttons while you turn on the printer, you can turn on the hex dump mode. This feature prints the codes that are sent to the printer so that advanced users can find the cause of communication problems between the computer and printer.
- Print settings** By holding down the **Pause** button while you turn on the printer, you can print the current DIP switch settings. See the next section for more information.
- Paper memory setting** By holding down the **Paper Select** button while you turn on the printer, you can register the paper form information when you use multi-part forms that overlap or forms with labels on them.

**Note:**

Before using your paper, check that it matches the specifications described earlier. Also make sure your paper has a straight edge.

If continuous paper is fed past the sprocket (on the last page, for example), the paper may not feed properly.

### Positioning the paper supply

You can load continuous paper from both the front and the rear, so be sure to leave enough room around the printer for the two stacks of fresh paper and for the printed stack. Make sure you align your paper supply with the paper loaded in the tractor so the paper feeds smoothly into the printer.

The following illustration shows three ways to position your printer and paper: with the front tractor loaded, with the rear tractor loaded, and with both tractors loaded.

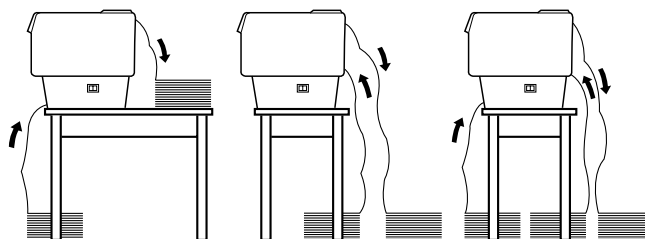

**Note:**

Make sure that your stack of printed pages does not interfere with the rear tractor's paper supply.

## Paper Handling

### Using the two-tractor system

Your printer's paper handling system consists of a front push tractor and a rear push tractor. Both tractors are easy to load and operate, and both accommodate a wide variety of paper types, including labels and multi-part forms. The printer automatically adjusts to the thickness of your loaded paper, so you don't need to make any manual adjustments to the paper thickness settings.

You can print on continuous paper from 4 inches (101 mm) to 16 inches (406 mm) wide. Your printer senses the paper width automatically.

When using more than two types of paper, load the paper you use most often onto the front tractor. The front tractor, which is easier to reach, will be available for the paper you change more frequently. Use only the front tractor for printing on labels, continuous forms with labels, overlapping multi-part forms, and overlapping multi-part forms with labels.

### What paper types you can use

You can use the continuous paper types listed below. (For some paper types, the rear tractor is not available.)

Continuous Paper Types	Front Tractor	Rear Tractor
Single-sheet	available	available
Multi-part	available	available
Labels	available	not available
Continuous forms with labels	available	not available
Overlapping multi-part forms	available	not available
Overlapping multi-part forms with labels	available	not available

### Adjusting the paper position

You can adjust the top-of-form position as well as the printing position at any point on the page by using the **TOF** and **Micro Feed** buttons. The printer then remembers the new top-of-form position. When you use the optional pull tractor, you can adjust the paper position as described below.

**Note:**

The printing position (based on the top-of-form position) is controlled by your software. To change the print position, adjust your software's print settings. Use the following procedure only if your software does not allow print position adjustment.

### Adjusting the top-of-form position

The top-of-form position is the position to which the printer feeds the paper when it loads it or performs a form feed. This position is important because it determines where the printing begins on each page. If the printing is too high or low on the page, you can adjust the top-of-form position either permanently or temporarily depending on how you use the TOF button.

- ❑ When you want to permanently change the top-of-form position, you enter the top-of-form mode using the **TOF** control panel button. The printer remembers the new top-of-form position even after the printer is turned off, reset, or initialized. (The printer remembers separate top-of-form positions for the front and rear tractors.)
- ❑ When you want to temporarily change the top-of-form position, you adjust the position using the **Micro Feed** buttons during pause status without entering top-of-form mode. The printer remembers the temporary top-of-form position until the next time you load paper, switch tractors, or turn off the printer.

You can set the top-of-form position from 2.6 mm (0.1 inch) to 33.9 mm (1.33 inch) below the top edge of the paper. The factory setting is 5.8 mm (0.2 inch).

Follow the steps below to reset (permanently change) the top-of-form position.

#### **CAUTION:**

To adjust the top-of-form position when labels are loaded in the printer, use the forward-feeding (top) Micro Feed button only; do not enter the top-of-form mode. Never feed labels backward through the printer.

1. Make sure the printer is turned on and the desired tractor is selected (the corresponding tractor arrow should be lit).
2. Open the top cover.
3. Press the **TOF** button to enter top-of-form mode. The printer beeps once, and the **TOF** light flashes. Also, the printer advances the paper so that the top-of-form position is lined up with the red line on the clear plastic ribbon protector.
4. Use the **Micro Feed** buttons to feed the paper to the desired top-of-form position. The red line on the ribbon protector shows you where the bottom edge of your first line of text will print. This position is based on the first printable line of

text. If your software inserts a top margin of five lines, your text will actually print five lines below the top-of-form position.

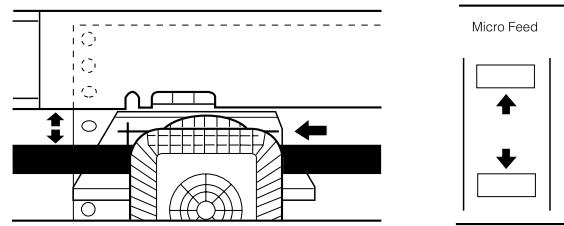

#### **Note:**

The red line on the ribbon protector can be used as a reference only when you are in top-of-form mode. At all other times your top-of-form position is hidden behind the print ribbon.

5. Press the **TOF** button again to exit and save your new top-of-form position. Then close the top cover.

#### **Note:**

If you enter top-of-form mode right after loading paper, you can set the loading and top-of-form positions at the same time. (When you use the optional pull tractor, you cannot adjust the loading position.)

### Adjusting the printing position

You may need to adjust the printing position in the middle of a page, or to adjust the top-of-form position when using labels.

When you move the printing position, you temporarily change the top-of-form position by the same amount. For example, if you adjust the printing in the middle of the page so that it falls a half-inch lower, the next page will begin printing a half-inch lower as well. The printer remembers this temporary top-of-form position until the next time you load paper, switch tractors, or turn off the printer. To adjust the printing position or top-of-form position, follow these steps:

1. Start printing your document. When you reach the text that you want to align at a particular spot on the page, press the **Pause** button to stop printing.
2. Use the **Micro Feed** buttons to adjust the position where you want your next line of text to fall. Press the button once to feed the paper forward or backward in 1/216-inch increments, or hold it down to move the paper continuously.

#### **CAUTION:**

If you are printing on labels, continuous forms with labels, or overlapping multi-part forms, use only the forward-feeding (top) Micro Feed button.

3. When you are finished, press the **Pause** button to resume printing your document.



## Tearing off the printed pages

After you finish printing, you can use the tear-off feature to advance continuous paper on the push tractor to the tear-off edge of the printer. You can then easily tear off printed sheets. When you resume printing, the printer automatically feeds paper back to the loading position.

This feature lets you save paper that would normally be lost between documents.

You can use the tear-off feature in two ways: by turning on DIP switch 3-1 to select automatic tear-off mode, or by pressing the **Tear Off** button on the control panel.

If the perforation between pages is not aligned with the tear-off edge, you can adjust the tear-off position using the micro-feed feature. The printer remembers this new tear-off position.

### CAUTION:

Never use the tear-off feature to reverse feed labels, overlapping multi-part forms, continuous forms with labels, or overlapping multi-part forms with labels. Do not use the tear-off feature when the optional pull tractor is installed or when using the paper memory feature.

### Tear-off mode

When you select tear-off mode with DIP switch 3-1, the printer automatically advances continuous paper to the tear-off position when you finish printing.

The printer advances paper to the tear-off position only when the printer receives a full page of data or a form feed command and no more data is received for three seconds.

Follow these steps to select tear-off mode:

1. Make sure the printer is turned off.
2. Turn DIP switch 3-1 on.
3. Turn the printer on.

When tear-off mode is on and you print on continuous paper on the push tractor, the printer advances the final printed page to the tear-off position. Then you can tear off all printed pages. If the perforation is not aligned with the tear-off edge, adjust the tear-off position.

When you resume printing, the printer automatically feeds the paper back to the loading position and begins printing.

### Using the Tear Off button

Whether or not the printer is in tear-off mode, you can use the **Tear Off** button to advance continuous paper to the tear-off position by following the steps below.

1. Make sure printing has finished. Then press the **Tear Off** button. The printer advances the paper to the tear-off edge and the **Tear Off** light comes on.

2. Tear off all printed pages. If the perforation is not aligned with the tear-off edge, adjust the tear-off position as described in the next section.
3. When you resume printing, the printer feeds the paper back to the loading position and begins printing. (You can also manually feed the paper back to the loading position by pressing the **Tear Off** button again.)

### Adjusting the tear-off position

If the paper's perforation is not aligned with the tear-off edge, follow these steps:

1. Turn on the printer and select the desired tractor.
2. Open the paper separator cover (the flap on the top part of the printer's top cover). This exposes the printer's tear-off edge.
3. Press the **Tear Off** button to enter the tear-off mode. The **Tear Off** light comes on and the printer feeds the paper's perforation to the printer's tear-off edge.

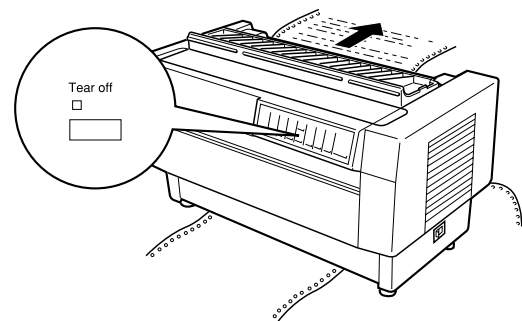

4. If the paper is not aligned with the tear-off edge, press the **Micro Feed** buttons to feed the paper forward or backward in 1/216-inch increments. (You can also hold down either **Micro Feed** button to feed the paper continuously.)

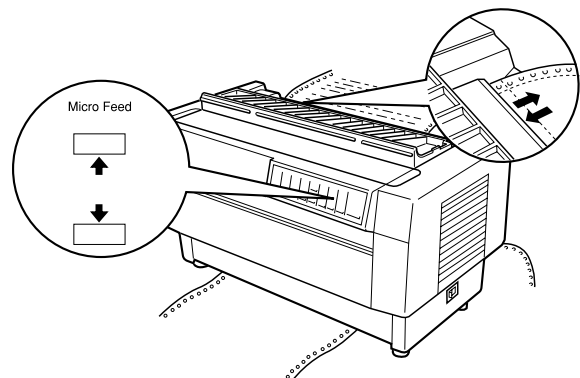

### Note:

You can reset the tear-off position only when you are in tear-off mode (after you press the **Tear Off** button once and the **Tear Off** light is on). The printer remembers the new tear-off position even after the printer is turned off, reset, or initialized.

5. Tear off the page using the tear-off edge on the printer's top cover.
6. Press the **Tear Off** button to feed the paper back to the top-of-form position. You are now ready to print your next document.

**CAUTION:**  
Always tear off the printed document before you feed the paper back to the top-of-form position. Never feed paper backward more than one page.

### Switching between front and rear tractors

You can easily switch between paper loaded on the front tractor and paper loaded on the rear tractor. The instructions below explain how to switch from the front tractor to the rear tractor, but you can follow the same steps to switch from the rear tractor to the front tractor.

**CAUTION:**  
Never switch between tractors if labels are already loaded in the printer. First remove the labels by tearing off the fresh supply below the tractor and pressing LF/FF Load to eject the remaining labels.

Before you start, make sure the printer is turned on and that the front tractor is selected (the front tractor arrow on the **Tractor Select** indicator should be lit). If you are in the middle of printing a document, wait for the printer to finish printing before you switch tractors. Then follow these steps:

1. If no paper is loaded in the rear tractor, load paper to the standby position (the first five pins of the sprockets).

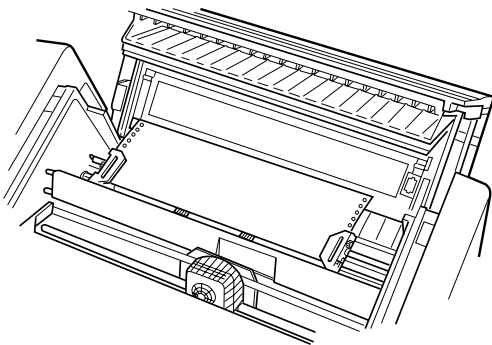

2. If you have a printed document or excess paper still in the printer, use the tear-off feature described in the previous section to tear off the document or excess paper.

**CAUTION:**  
Always tear off the printed document and any excess paper before switching tractors. Never feed more than one page backward through the printer.

3. Press the **Front/Rear** button to switch to the rear tractor. The front-loaded paper automatically feeds back to the standby position and the rear-loaded paper advances to the top-of-form position.

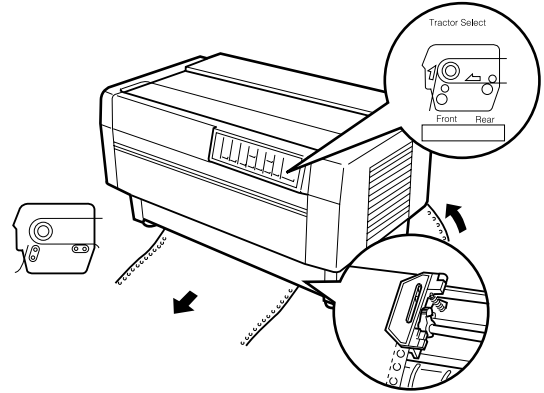

### Replacing the Ribbon Cartridge

When printing becomes too faint, you need to replace the ribbon. Use the #8766 EPSON replacement cartridge only.

**WARNING:**  
If the printer has been used recently, the print head may be hot. Let it cool before attempting to replace the ribbon.

### Removing the old ribbon cartridge

To remove the ribbon cartridge, follow these steps:

1. Press the **Pause** button. Then turn off the printer. Make sure that the power cord is not plugged into an electrical outlet.
2. Open the printer's top cover and slide the print head to the exposed part of the paper bail.
3. Lift the ribbon guide off the print head as shown below.

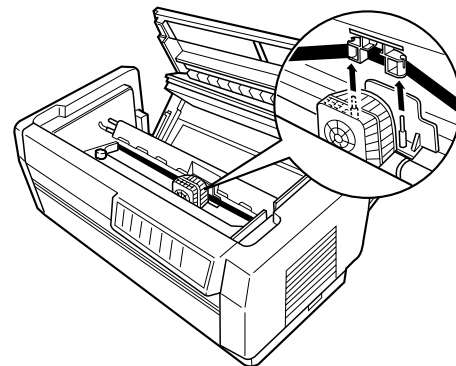

4. Pull up on the side of the ribbon cartridge as shown below to release it from the printer's mounting pins. Remove the cartridge by lifting it up and away from you.

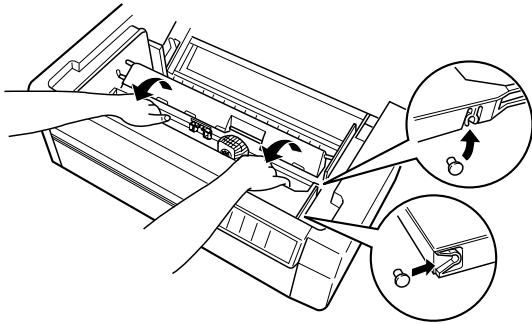

**CAUTION:**  
Make sure you don't pull on the flat gold cable beneath the ribbon cartridge.

### Installing the new ribbon cartridge

Before installing the ribbon cartridge, make sure that the protective packing materials have been removed. Remove the ribbon cartridge from the box and plastic bag. Then follow these steps:

**WARNING:**  
Never move the print head while the printer is turned on unless instructed to because this can damage the printer. Also, if you have been using the printer, the print head may be hot; let it cool for a few minutes before touching it.

1. Remove the separator from the middle of the ribbon cartridge and discard it. Then detach the ribbon guide from the cartridge (but not from the ribbon) and turn the ribbon-tightening knob in the direction of the arrow to take up any slack in the ribbon.

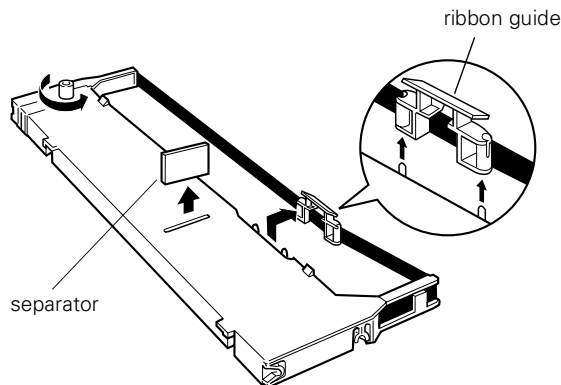

2. Hold the ribbon cartridge with both hands and lower it into the printer as shown below. Pulling the cartridge toward you, slide the notches nearest you over the two

corresponding pins in the printer. Then push the cartridge down into position until the other two slots snap into place over the mounting pins in the printer.

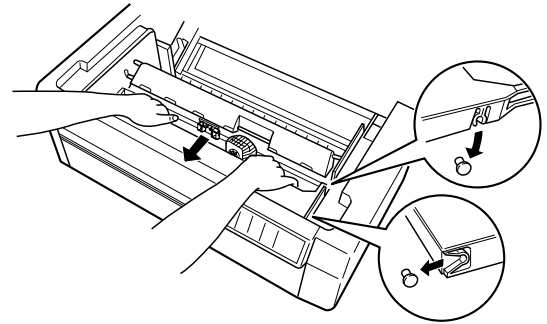

3. Press lightly on both sides of the cartridge to make sure it is locked in place.
4. Insert the ribbon guide over the metal pins on each side of the print head as shown below. The smaller end of the guide should be on top, with its angled edge facing back toward the platen. Turn the ribbon-tightening knob again to remove any slack in the ribbon.

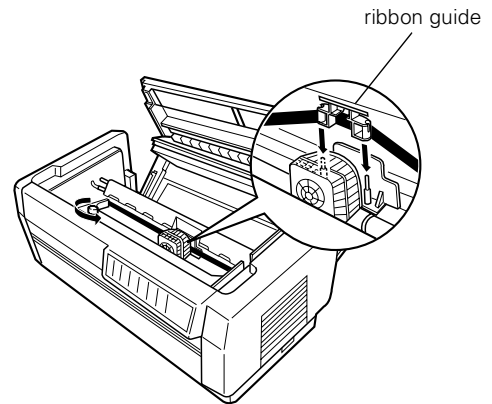

5. Slide the print head from side to side to see that it moves smoothly and that the ribbon is not twisted or creased.

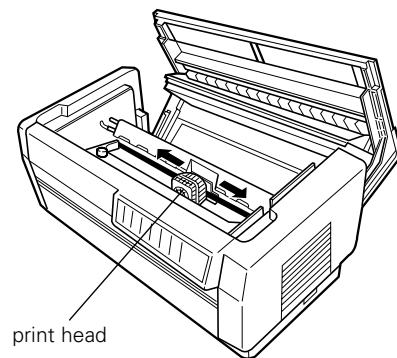

6. Close the top cover.

## Error Indicators

You can identify many common printer problems with the lights on the control panel. If your printer stops working and the lights are on or flashing, use the following table of panel light patterns to diagnose and solve the problem.

State of panel light	Beep pattern	Problem and solution
<input type="checkbox"/> Paper Out <input type="checkbox"/> Pause	•••	<b>No paper is loaded in the printer.</b> Load paper in the printer. The Paper Out light turns off and the printer resumes printing.
	•••	<b>The paper is not loaded correctly.</b> Remove and reload paper correctly. See the instructions for loading paper beginning on page 7.
<input type="checkbox"/> Paper Out <input type="checkbox"/> Pause	•••••	<b>Paper has jammed in the printer.</b> To clear the paper jam, see "Clearing Paper Jams" on page 12.
		<b>Ribbon has jammed.</b> Remove and re-install the ribbon cartridge. See "Replacing the Ribbon Cartridge" on page 10.
<input type="checkbox"/> Paper Out <input type="checkbox"/> Ribbon <input type="checkbox"/> Pause	•••••	<b>The loaded paper may be thicker than the specified ranges.</b> Press the Pause button. The printer starts printing very slowly. Make sure that the paper thickness is within the specified ranges. See the paper specifications on page 2.
		<b>The print head is overheated.</b> Wait a few minutes; the printer will resume printing automatically once the print head cools.
<input type="checkbox"/> Pause	–	<b>The printer top cover is open.</b> Close the cover and press the Pause button.
<input type="checkbox"/> Pause	•••	<b>The paper selected does not match the paper loaded in the printer.</b> Load the correct paper or select the appropriate paper setting.
		<b>The printer fails to switch to and feed the proper paper.</b> Remove any paper in the printer and then press the Pause button to reload the paper you selected.

State of panel light	Beep pattern	Problem and solution
<input type="checkbox"/> all lights + Paper Select indicates "E" followed by a number.	–	<b>An unknown printer error has occurred.</b> Turn off the printer and leave it for several minutes; then turn on the printer again. If the error occurs again, contact your dealer.  The printer may turn off all lights after 12 seconds. Also in this case, turn off the printer and leave it for several minutes; then turn on the printer again. If the error occurs again, contact your dealer.

= on,  = flashing

••• = short interval, ••••• = long interval

## Clearing Paper Jams

To clear a paper jam, follow these steps:

1. Turn off the printer.
2. Open the printer's top cover.
3. Remove continuous paper from the printer if it is loaded. If continuous paper is jammed in the printer, tear off the fresh supply at the front or rear of the printer.
4. If the paper is caught in the paper ejection area, gently pull it out of the printer.
5. Close the printer cover and turn the printer back on. Make sure the Paper Out light is not flashing and the Pause light is not on.

## Printing a Self Test

Running the printer's self test helps you determine whether the problem comes from the printer or the computer:

- If the self test results are satisfactory, the printer is working properly and the problem is probably caused by your printer driver settings, application settings, computer, or interface cable. (Be sure to use a shielded interface cable.)
- If the self test does not print properly, there is a problem with the printer.

To perform a self test, follow these steps:

1. Make sure that the printer is turned off and that the paper is set on the front or rear tractor.

**CAUTION:**

Whenever you turn off the power, wait at least five seconds before turning it back on; otherwise you may damage the printer.

2. While holding down the **LF/FF Load** or **Tear Off** button, turn on the printer. The **LF/FF Load** button performs a draft self test. The **Tear Off** button performs a near letter quality (NLQ) self test.

In a few seconds, the printer starts the self test, in which a series of characters is printed.

**Note:**

If you want to temporarily stop the self test, press the **Pause** button. To resume the test, press the **Pause** button again.

3. To end the self test, press the **Pause** button to stop printing. Tear off the page if necessary, and then turn off the printer.

**CAUTION:**

Do not turn off the printer while it is printing. Always press the **Pause** button to stop printing and then turn off the printer.

## Printing a Hex Dump

The printer can print data in hex dump mode, which allows experienced users to find the cause of communication problems between the printer and a software program. In hex dump mode, the printer prints all data received as characters in hexadecimal values.

To use hex dump mode, follow these steps:

1. Make sure that paper is loaded in the printer.
2. Hold down both the **LF/FF Load** and **Tear Off** buttons while you turn on the printer.
3. Next, run a software program and send a print job to the printer. Your printer prints all the codes it receives from the software in hexadecimal format.

By comparing the characters printed in the right column with the printout of the hexadecimal codes, you can check the codes being received by the printer. If characters are printable, they appear in the right column as ASCII characters. Nonprintable codes, such as control codes, are represented by dots.

4. To turn off hex dump mode, press the **Pause** button, and then turn off the printer.

## Cleaning the Printer

To keep your printer operating at its best, you should clean it thoroughly several times a year. Follow these steps:

1. Turn off the printer and close all of its covers. Then remove any paper as well as the paper guide. If you have installed the optional pull tractor, perforation cutter, or paper cutter, remove it.
2. Use a soft brush to carefully brush away all dust and dirt from the outer case.
3. If the outer case or paper guide is still dirty or dusty, clean it with a soft, clean cloth dampened with mild detergent dissolved in water. Keep all of the covers closed to prevent water from getting inside the printer.

**WARNING:**

Be careful not to get water on the printer mechanism or electronic components.

**CAUTION:**

Never use alcohols or thinners to clean the printer. These chemicals can damage the printer components as well as the case.

Do not use a hard or abrasive brush.

Do not spray the inside of the printer with lubricants; unsuitable oils can damage the mechanism. Contact your EPSON dealer if you think lubrication is needed.

## Transporting the Printer

If you need to transport your printer some distance, carefully repack it using the original box and packing materials as described below.

**WARNING:**

Even when you need to carry the printer only a short distance, do not carry it by yourself. The printer should always be carried by two people holding the printer at the bottom.

1. Turn off the printer and remove any paper loaded in the printer. If any printer options are installed, remove them.
2. Unplug the power cord from the electrical outlet and the back of the printer. Disconnect the interface cable from the printer.
3. Remove the ribbon cartridge.
4. Install the protective materials onto the printer as shown on the Notice Sheet.
5. Repack the printer, ribbon cartridge, and power cord in the original packing materials and place them in the printer's original box.

## Options

### Optional Interfaces

You can use optional interface cards to supplement your printer's built-in serial and parallel interfaces. The EPSON interface cards below are compatible with your printer. (Not all of these interfaces are available worldwide.)

Number	Name
C823051	Serial interface
C823071	32KB intelligent serial interface
C823121	Local Talk interface
C823141	Coax interface
C823151	Twinax interface
C823452	Bi-directional parallel interface
C823572	Multiprotocol Ethernet interface

### Optional Perforation Cutter Specifications

The specifications below apply to the optional perforation cutter (C815071).

#### Paper

Width:	4 to 16 inches (101 to 406 mm)
Length/page:	4 to 17 inches (101 to 431 mm)
Number of copies:	7 sheets (1 original + 6 copies)
Total thickness:	0.021 inch (0.53 mm) maximum
Weight:	
Single sheets:	14 to 22 lb (52.6 to 82.7 g/m <sup>2</sup> )
Multi-part forms:	11 to 15 lb (41.4 to 56.4 g/m <sup>2</sup> ) × <i>n</i> ( <i>n</i> ≤ 7) and within the total thickness

#### Note:

You cannot use labels, overlapping multi-part forms, continuous forms with labels, or overlapping multi-part forms with labels.

#### Environmental

Temperature:

Operation:	41° to 95°F (5° to 35°C)
Storage:	-22° to 140°F (-30° to 60°C)

Humidity (without condensation):

Operation:	10% to 80% RH
Storage:	5% to 85% RH

Dimensions and weight:

Height:	5.1 inches (130 mm)
Width:	20.1 inches (510 mm)
Depth:	4.3 inches (110 mm)
Weight:	6.4 lb (2.9 kg)

### Optional Paper Cutter Specifications

The specifications below apply to the optional paper cutter (C815001).

#### Paper

Width:	4 to 16 inches (101 to 406 mm)
Labels:	2.5 × 15/16 inches 4 × 15/16 inches 4 × 17/16 inches
Number of copies:	6 sheets (1 original + 5 copies)

#### Environmental

Temperature:

Operation:	41° to 131°F (5° to 55°C)
Storage:	-22° to 158°F (-30° to 70°C)

Humidity (without condensation):

Operation:	10% to 80% RH
Storage:	0% to 95% RH

Dimensions and weight:

Height:	4.6 inches (117 mm)
Width:	20.4 inches (518 mm)
Depth:	3.7 inches (93 mm)
Weight:	11 lb (5 kg)

## Related Documentation

4007064	EPSON DFX-8500 User's Guide
TM-DFX8500	EPSON DFX-8500 Service Manual
PL-DFX8500	EPSON DFX-8500 Parts List